

# ELECTRIC TREATMENT TABLE

# CONFYCARE

## 3 SECTIONS

- Electric height adjustable by footbar system (18.5" - 36.6")
- 4 multidirectional casters
- Cushions thickness: 2"
- The frame is designed to add an extension, or a half-moon headrest
- Loading weight: 495 lbs (225 kgs)
- Paper roll holder available as option
- Certification:  
Tested according to the Canadian standard by QPS  
CE, FDA, ISO 9001-2008, ISO 13485-2007
- Warranty:
  - Motor/Control box: 5 years
  - Frame: 5 years
  - Cushions: 3 years
  - Parts/Cylinder: 1 year
  - Labor: 1 year

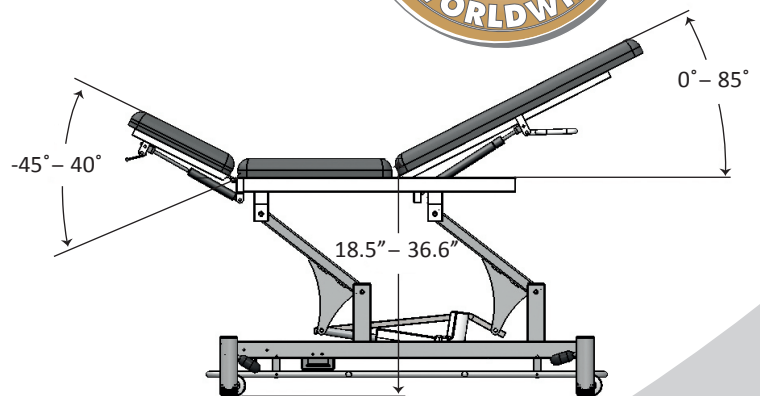
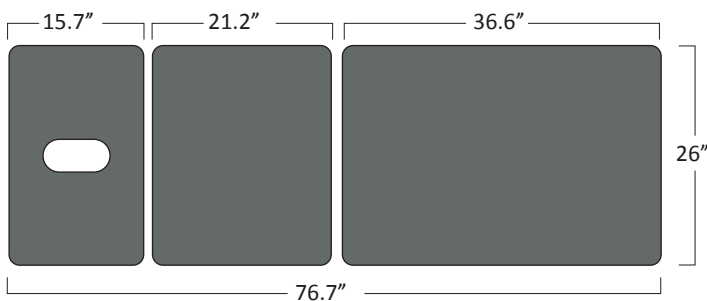

### AVAILABLE COLOURS

- |          |       |          |           |
|----------|-------|----------|-----------|
| CUSHIONS | BLACK | CHARCOAL | NAVY BLUE |
| FRAME    | IVORY | GRAPHITE |           |

DISTRIBUTED BY



190, Boul. St-Elzéar Ouest  
Laval (Québec) H7L 3N3  
T 450 669.8985 | 1 800 361.0877  
F 450 669.9532 | 1 888 935.7001

[www.mtm.ca](http://www.mtm.ca)