

# ELECTRIC TREATMENT TABLE

# CONFY CARE

## 5 SECTIONS

- Electric height adjustable by footbar system (19.7" - 37.8")
- 4 multidirectional casters
- Cushions thickness: 2"
- Loading weight: 495 lbs (225 kgs)
- Paper roll holder available as option
- Certification: tested according to the Canadian standard by QPS  
CE, FDA, ISO 9001-2008, ISO 13485-2007
- Warranty:
  - Motor/Control box: 5 years
  - Frame: 5 years
  - Cushions: 3 years
  - Parts/Cylinder: 1 year
  - Labor: 1 year

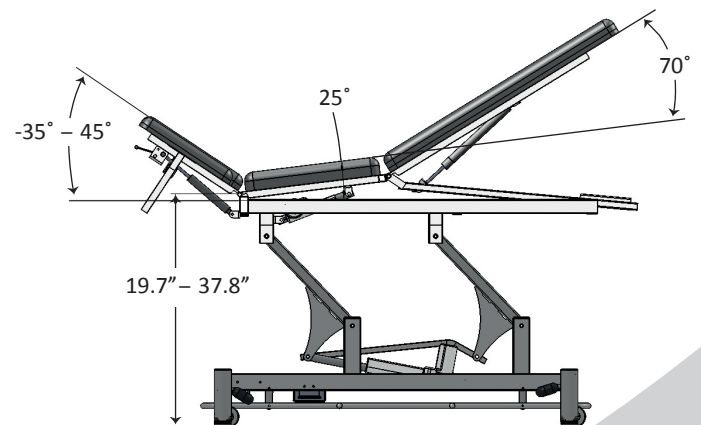
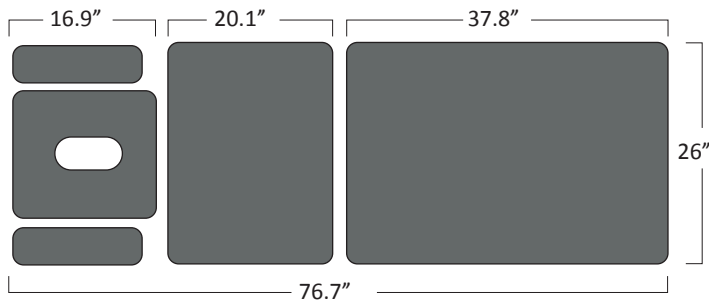

## AVAILABLE COLOURS



BLACK



CHARCOAL



NAVY  
BLUE

DISTRIBUTED BY



190, St-Elzéar West Blvd.  
Laval (Québec) H7L 3N3  
T 450 669.8985 | 1 800 361.0877  
F 450 669.9532 | 1 888 935.7001

[www.mtm.ca](http://www.mtm.ca)