

TR 1000

Battery Operated Shower Chair



Safe - Dignified - Comfortable - Efficient Showering at its best

The TR 1000 Battery operated shower chair is height adjustable and can be tilted backward and forward for easy and efficient transfers and showering.

The TR 1000 height adjustable shower chair is a great solution to minimize static load and offers a safe and ergonomic working environment for caregivers. The full power feature of the TR1000 allows the caregiver to use the hand control to adjust the height and tilting of the chair so that they can best position the resident to care for their individual needs. This provides a safe patient handling environment for both the resident and the caregiver. The chair can be tilted and adjusted to shower the residents hair, and then adjusted to shower the feet. The TR1000 offers a dignified work situation for the caregiver while a resident is comfortably positioned in the efficient and easily accessible height adjustable shower chair.

The resident will experience a relaxing and dignified showering experience while seated in the TR 1000 and reclined to a suitable position for comfort and care. Being able to interact with the caregiver during the complete process increases the sense of a dignified experience and increased mobility.

The TR 1000 is designed to offer a safe experience for the resident thanks to stability, easy access during transfer and showering, in addition to smooth height adjustments and reclining. The armrests are shaped for the resident to feel secure when sitting in the chair and the headrest offers support when reclining.

Besides showering the TR 1000 can also be used for other tasks such as transportation, toileting and pedicure.

TR 1000 Features:



Wide height adjustment range with smooth and gentle movement to give residents and caregivers a safe and comfortable showering and shampooing experience.



Recline position for the residents comfort and relaxation and allowing easy access for caregiver.



The forward tilt adjustment mechanism allows easier transfers from wheelchairs and standing aids and creates security for both resident and caregiver.

TR EQUIPMENT

TR EQUIPMENT AB PO Box 116, S-573 22, TRANÅS, SWEDEN
TR GROUP INC. 2990 NORTH PERRYVILLE RD, STE 2300, ROCKFORD, IL 61107, USA
TR EQUIPMENT UK LTD. INNOVATION CENTRE, GALLOWS HILL, WARWICK CV34 6UW ENGLAND
TRANSPORHAMED GMBH GRÜNBAUMSTR. 89 42659 SOLINGEN. GERMANY

Phone: +46 140-38 50 60 Fax: +46 140-38 50 61
Phone: +1 800-752-6900 Fax: +1 815 633-0549
Phone: +44 844 335 8386 Fax: +44 844 335 8383
Phone: +49 (0) 212-645850-0 Fax: +49 (0)212-645850-50

Hygiene Equipment Designed for People

www.trequipment.com



TR 1000

Battery Operated Shower Chair



Seat and backrest are designed for ease of comfort and cleanliness.



The headrest provides support and security for the residents head and neck.



Columns for height adjustment give gentle and smooth movement and provide a clean design.



Foldable armrests feature grip knobs for resident's comfort and safety.



The integrated leg rest is designed for residents comfort and ergonomic working routines.



The bed pan accessory option can be fitted to the chair to ease toileting.



Easy to understand hand control for height adjustment and tilt from any position around the chair.



Removable battery packs are easy to change making the TR 1000 simple to charge and always ready for use.



The foldable armrest accessory option features front closing for increased sense of security for residents.

Features

- Clean design of chassis and chair make access easy during transfers and showering. It also makes the TR 1000 easy to clean.
- Suitable to use with most sling hoists and standing/raising aids to make transfers as smooth and safe as possible.
- Seat and chassis create possibilities for toileting over standard toilet or with a bed pan attached to the chair.
- Designed for stability and for ease in mobility and transfers.
- The rear chair design features a smooth surface for ease of cleaning.
- Belt over the hip feature for patient safety.
- The adjustable and foldable footrest ensures security and comfort for residents (available option).

Models

Shower chair with straight armrests
Shower chair with front closing armrests

Accessories / Options

Adjustable and foldable footrest
Bed pan including lid

Distributor:



190, Boul. St-Elzéar Ouest
Laval (Québec) H7L 3N3
T 450 669.8985 | 1 800 361.0877
F 450 669.9532 | 1 888 935.7001

www.medicaltronik.ca

TR reserves the right to make design changes and/or improvements without notice
TR EQUIPMENT

Specifications

Lifting stroke range	400 mm (16")
Working Load Limit	200 kg (440 lbs)
Tilt backwards (recline)	25 degrees
Tilt forward	7 degrees
Structure	Powder coated, zinc plated steel and stainless steel
Castors	Twin Ø100 mm (4") castors with locking brakes
Control	Hand control for height adjustment and tilt
Battery	Removable and rechargeable 24 V



Registered at Medical Products Agency, Sweden, as a MD Class 1, MDD 93/42EEC.

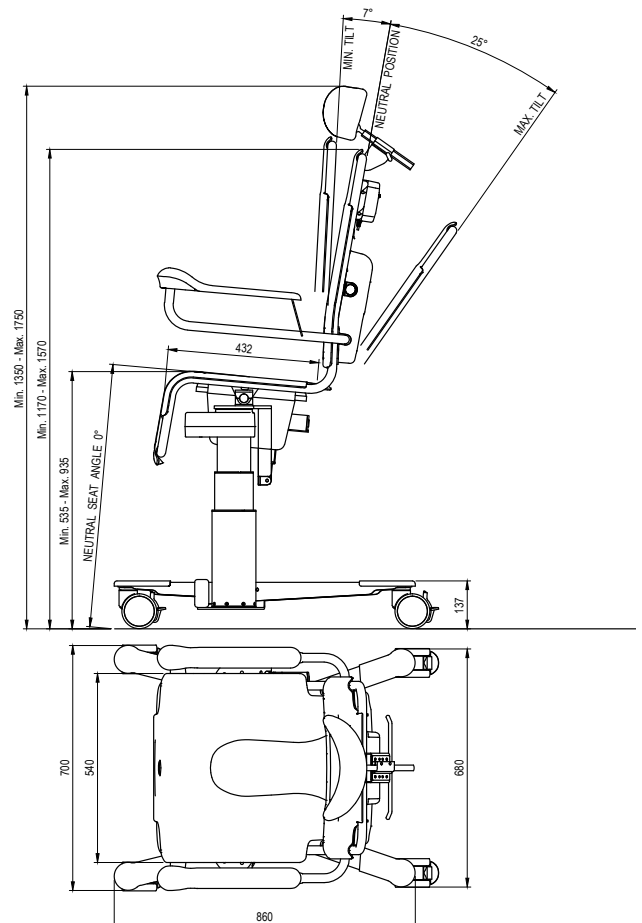

Manufacturer: TR Equipment AB, Sweden

Hygiene Equipment Designed for People

TR EQUIPMENT AB

PO Box 116, S-573 22, TRANÅS, SWEDEN

Phone: +46 140-38 50 60

Fax: +46 140-38 50 61

TR GROUP INC.

2990 NORTH PERRYVILLE RD, STE 2300, ROCKFORD, IL 61107, USA

Phone: +1 800-752-6900

Fax: +1 815 633-0549

TR EQUIPMENT UK LTD.

INNOVATION CENTRE, GALLOWES HILL, WARWICK CV34 6UW ENGLAND

Phone: +44 844 335 8386

Fax: +44 844 335 8383

TRANSPOREHAMED GMBH

GRÜNBAUMSTR. 89 42659 SOLINGEN. GERMANY

Phone: +49 (0) 212-645850-0

Fax: +49 (0)212-645850-50

www.trequipment.com

